

Painted Black, Boltdown, Steel Checker Plate Lids
Options: Galvanizing, Padlock Recess
 Remote Reader Holes
 Weld Marking e.g. "ELEC"

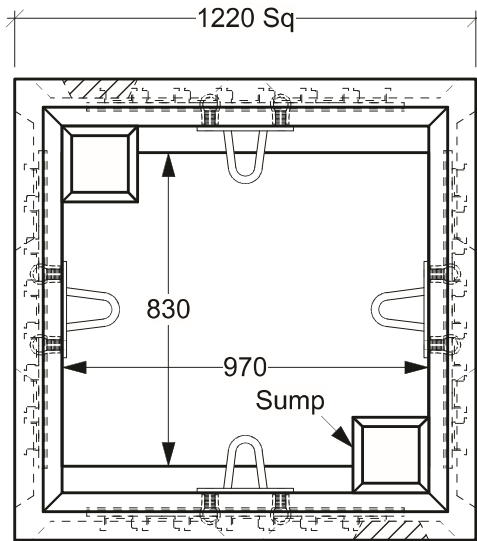

Plan View - Vault

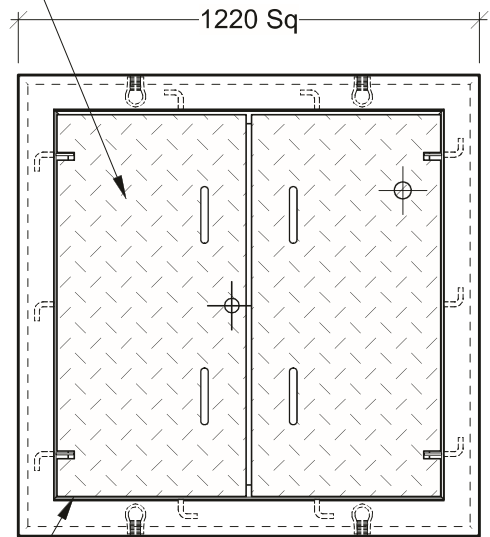

Plan View - Collar

Cable Support Channel
 (Typ 1 per Wall)

2 Hole Pulling Iron
 Each Wall (Typ 4)

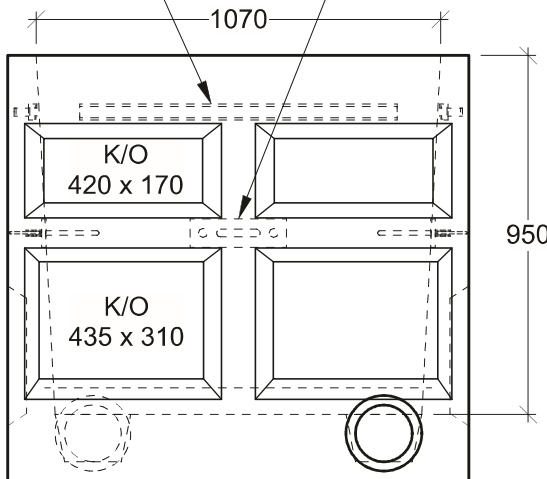

Side View

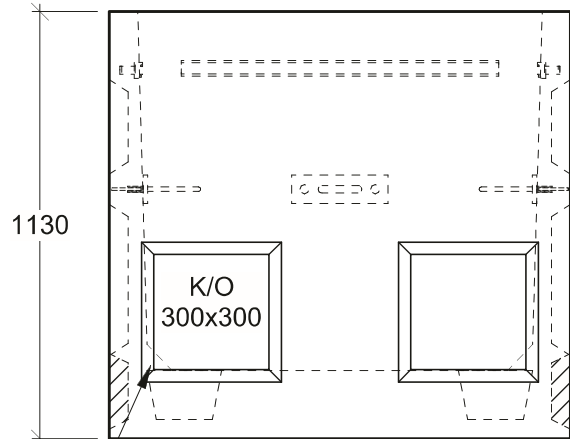
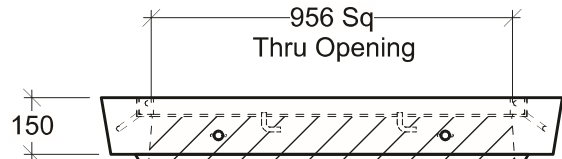

End View

25Ø Pulling Insert
 (Typ 4)

General Notes:

- Product manufactured in accordance with CSA A23.4
- Lift Points Provided (See Shop Drawing for Quantity & Locations)
- Site Installation, Backfilling, Suitability for Use and Engineering Design Approval is the responsibility of others



19060 - 54th Avenue
 Surrey, B.C. V3S 8E5

Tel (604) 576-1808
 info@aeconcrete.com

1.2m Highways Medium Junction Vault

Vault: 3,410 lbs / 1,550 kgs
 Collar: 720 lbs / 330 kgs

Scale: 1:20mm

Rev: 28Jun08

Dwg#: **SVHZ-2B-1200-C**