

Plan View - Top

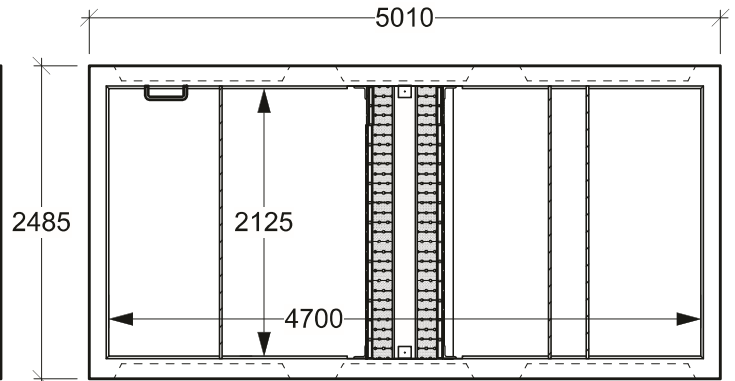

Plan View - Bottom

H-20 Traffic Load Rated

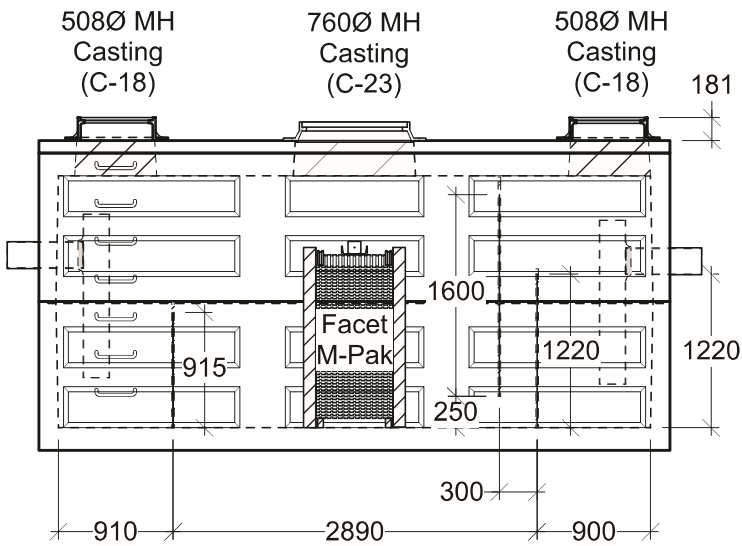

Side View

Typical Minimum Depth from Grade to Outlet Invert with MH Castings = 1240 mm

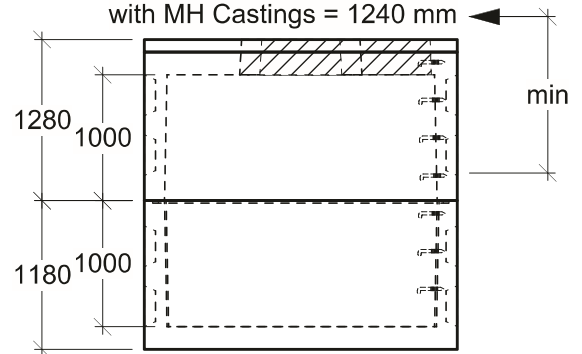

End View

General Notes:

- Product manufactured in accordance with CSA A23.4
- Designed for Roadway Use - H-20 Traffic Loading
- Lift Points Provided (See Shop Drawing for Quantity & Locations)
- Installation of T-Pipe Assemblies Recommended - Installed by Others
- Standard Mild Steel Baffles - Optional Galvanized Baffles
- Site Installation, Backfilling & Suitability for Use is the responsibility of others



19060 - 54th Avenue
Surrey, B.C. V3S 8E5

Tel (604) 576-1808
info@aeconcrete.com

4712 Oil Separator (CPS)

Oil Sep:
51,180 lbs / 23,230 kgs

Scale: 1:50 mm

Rev: 28Jun08

Dwg#: **VC47-20-ZZZZ-CPS-C**