

Plan View

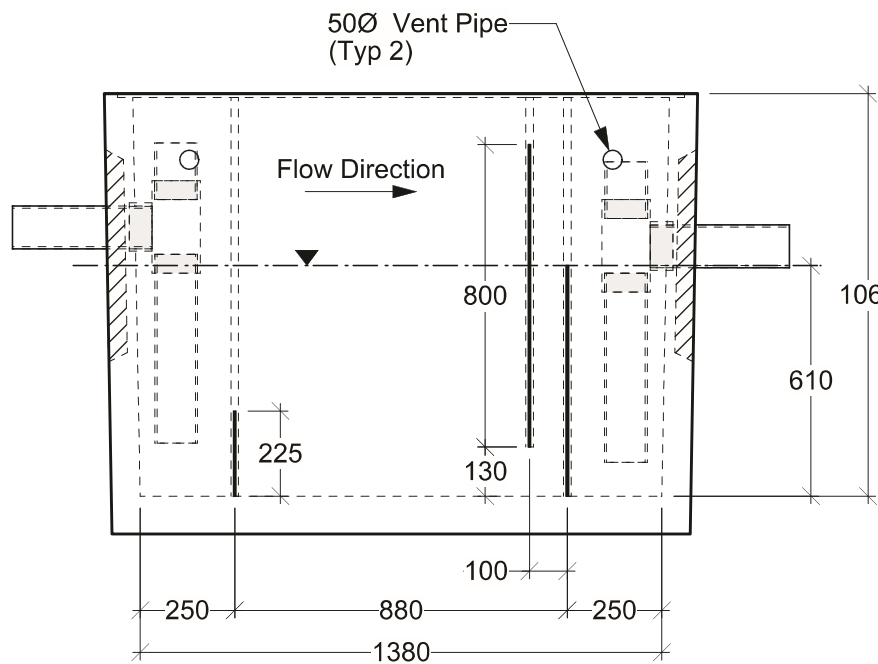

Side View

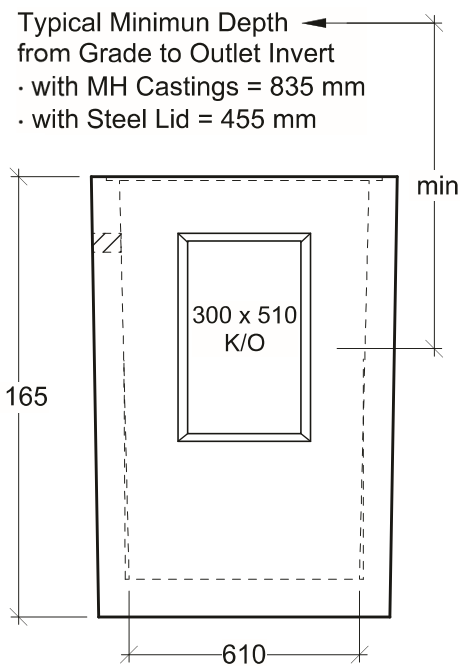

End View

General Notes:

- Product manufactured in accordance with CSA A23.4
- Lift Points Provided (See Shop Drawing for Quantity & Locations)
- Designed for Roadway Use - H-20 Traffic Loading
- Installation of T-Pipe Assemblies Recommended - Installed by Others.
- Standard Mild Steel Baffles - Optional Galvanized Baffles
- Up-gradable with Facet "M-Pak" Coalescing Plate System - Design/Build
- Site Installation, Backfilling & Suitability for Use is the responsibility of others



19060 - 54th Avenue
Surrey, B.C. V3S 8E5

Tel (604) 576-1808
info@aeconcrete.com

2454 Oil Interceptor (API)

Oil Int: 2,610 lbs / 1,190 kgs

Scale: 1:20 mm

Rev: 28Jun08

Dwg#: **24OI-20-1420-API-C**