

Plan View - Top

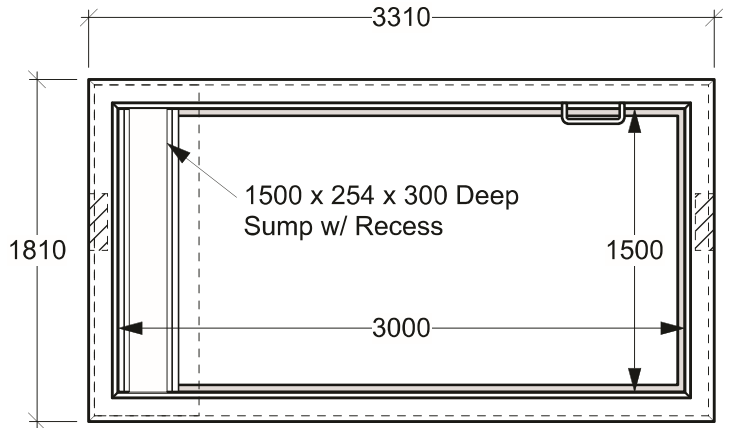

Plan View - Bottom

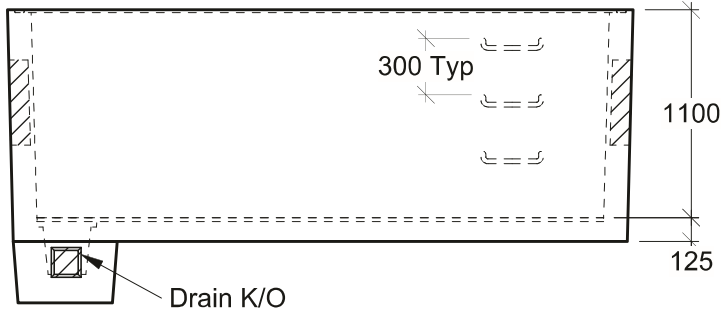
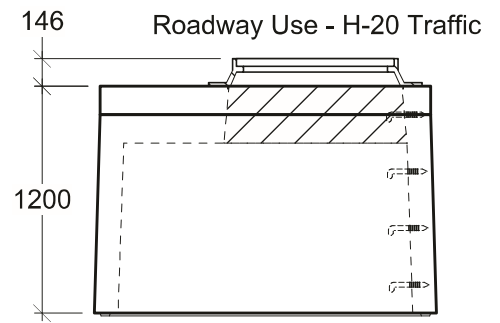
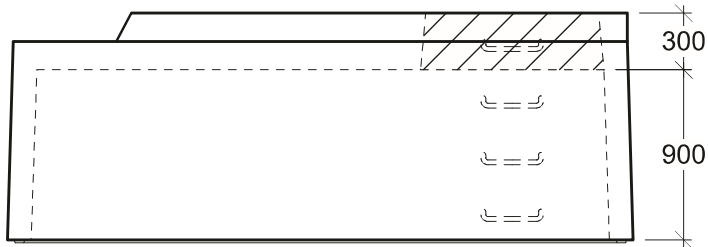

SideView

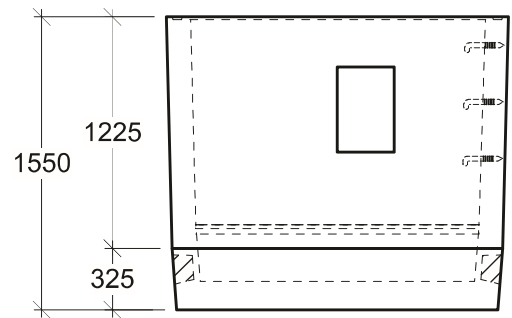

End View

General Notes:

- Lift Cables Provided
- Cement to CSA A-3001 Portland Cement
- Reinforcing Steel to CSA G-30.18-M Grade 400
- Minimum Concrete Strength 30 MPa @ 28 Days
- Site Installation and Backfilling are the Responsibility of Others
- Design and Provision of Thrust Blocks is the Responsibility of Others



19060 - 54th Avenue
Surrey, B.C. V3S 8E5

Tel (604) 576-1808
info@aeconcrete.com

3152 Chamber - Burnaby Std w/ MH Entry

Top: 12,100 lbs / 5,480 kgs
Btm: 12,500 lbs / 5,660 kgs

Scale: 1:40 mm

Rev: 28Jun08

Dwg#: **VC31-20-09BU-C**